



For more Hi-Fi manuals and set-up information
please visit www.hifiengine.com

ONKYO SERVICE MANUAL

Ref. No. 3390

STEREO CASSETTE TAPE DECK MODEL TA-RW404

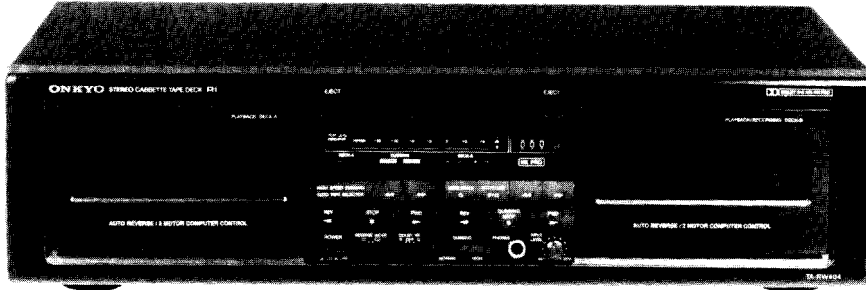

Black model

UDN, UDC, UD	120V AC, 60Hz
UP	230V AC, 50Hz
UW	120 or 220V AC, 50/60Hz

SAFETY-RELATED COMPONENT WARNING!!

COMPONENTS IDENTIFIED BY MARK Δ ON THE SCHEMATIC DIAGRAM AND IN THE PARTS LIST ARE CRITICAL FOR RISK OF FIRE AND ELECTRIC SHOCK. REPLACE THESE COMPONENTS WITH ONKYO PARTS WHOSE PART NUMBERS APPEAR AS SHOWN IN THIS MANUAL.

MAKE LEAKAGE-CURRENT OR RESISTANCE MEASUREMENTS TO DETERMINE THAT EXPOSED PARTS ARE ACCEPTABLY INSULATED FROM THE SUPPLY CIRCUIT BEFORE RETURNING THE APPLIANCE TO THE CUSTOMER.

SPECIFICATIONS

Track System:	4-tracks, 2-channels
Erasing System:	AC erase
Tape Speed:	4.8 cm/sec. (1-7/8 i.p.s.) 9.6 cm/sec. (3-3/4 i.p.s.) (high speed dubbing)
Wow and Flutter:	0.07% (WRMS)
Frequency Response:	20 – 15,000Hz (Normal) (30 – 14,000Hz \pm 3dB) 20 – 16,000Hz (High) (30 – 15,000Hz \pm 3dB) 20 – 17,000Hz (Metal) (30 – 16,000Hz \pm 3dB)
S/N Ratio:	Dolby NR off: 58dB (metal position tape) A noise reduction of 10dB above 5kHz and 5dB at 1kHz is possible with Dolby B NR. A noise reduction of 20dB at 5kHz is possible with Dolby C NR.
Input Jacks:	Line IN: 2 Input sensitivity: 80mV Input impedance: 50 kohms
Outputs:	Headphone jack: 1 Optimum load impedance: 8 to 200 ohms Line OUT: 2 Standard output level: 500mV (0dB) Optimum load impedance: over 50 kohms
Motors:	DC servo motor x 2; DC motor x 2
Heads:	REC/PB: 1 PB: 1 ERASE: 1
Power Supply Rating:	European models: AC 230V, 50Hz Canadian models: AC 120V, 60Hz Worldwide models: AC 120V and 220V switchable, 50/60Hz
Power Consumption:	34 watts
Dimensions:	455(W) x 120(H) x 306(D)mm (17-15/16" x 4-3/4" x 12-1/16")
Weight:	5.5 kg. (12.1 lbs.)

Specifications and external appearance are subject to change without notice because of product improvements.

ONKYO

AUDIO COMPONENTS

BLOCK DIAGRAM

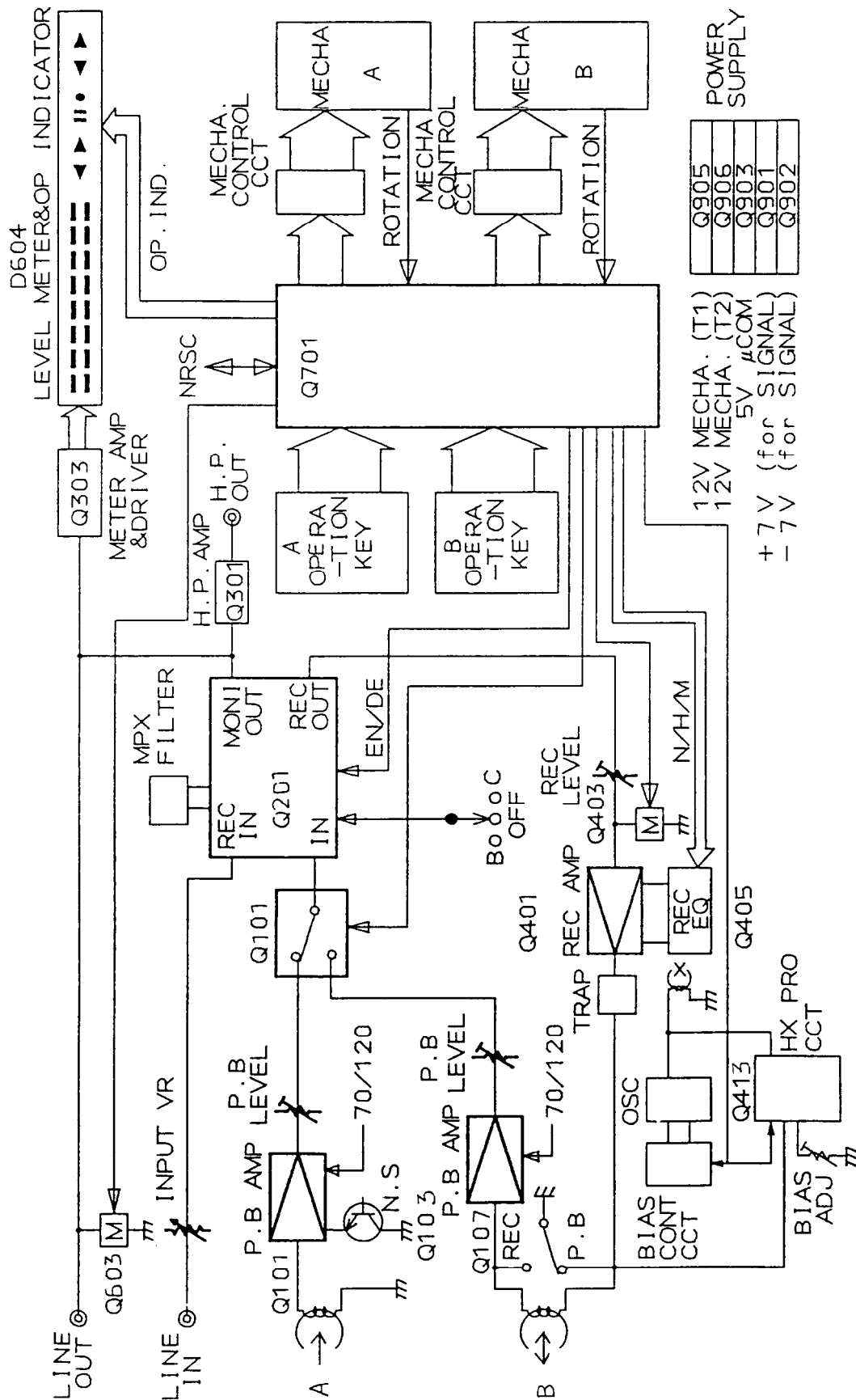

IC BLOCK DIAGRAM

HA12142NT (DOLBY NR)

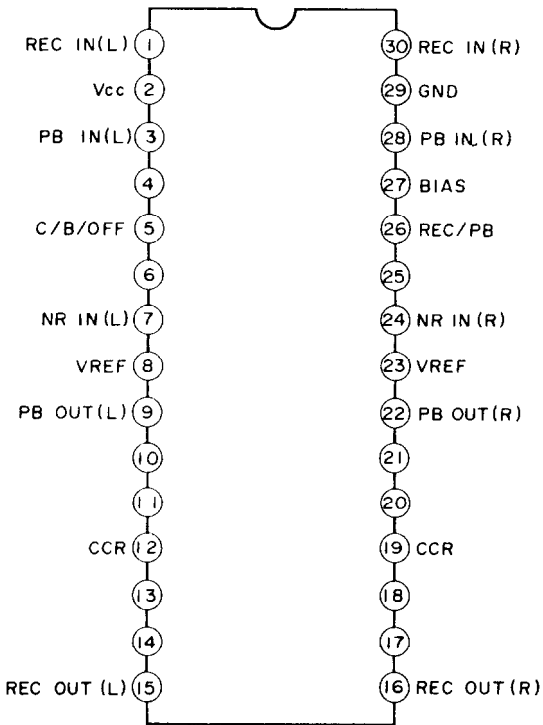

μPC1330HA (REC/PB SW)

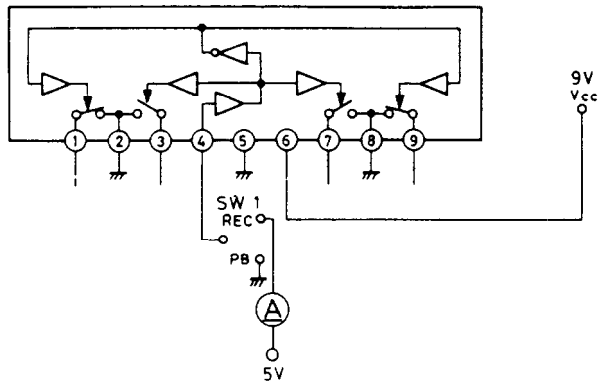

CXA1198A (REC EQ)

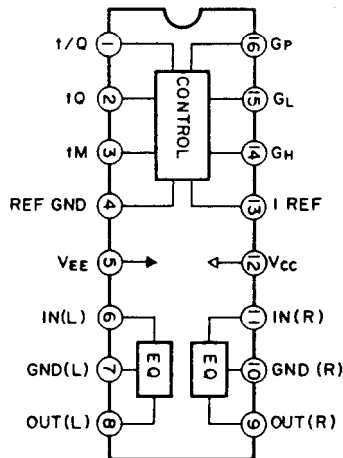

4051B (ANALOG SW)

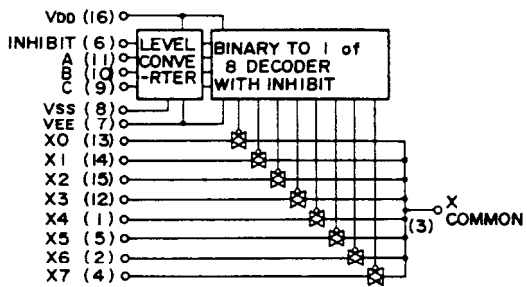

INHIBIT	A(11)	B(10)	C(9)	ON SWITCH
L	L	L	L	X0 (13)
L	H	L	L	X1 (14)
L	L	H	L	X2 (15)
L	H	H	L	X3 (12)
L	L	L	H	X4 (1)
L	H	L	H	X5 (5)
L	L	H	H	X6 (2)
L	H	H	H	X7 (4)
H	X	X	X	NONE

X: Don't Care

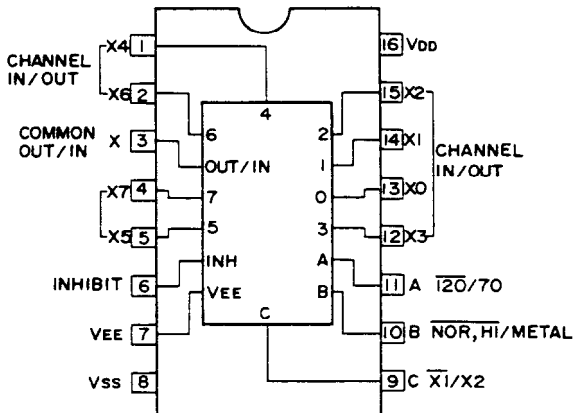

MICRO COMPUTER PORT NAMES AND FUNCTION (HD614049SA83)

No.	Name	IN/OUT	Function
1	X1 DUBBING LED	O	Dubbing indication, H:ON
2	X2 DUBBING LED	O	Dubbing indication, H:ON
3	T1 REV. LED	O	REV play indication, H:ON
4	T1 FWD. LED	O	FWD play indication, H:ON
5	REC. MUTE	O	Recording muting, H:ON
6	INPUT SEL. T2/T1	O	T1/T2 play back signal selection
7	BIAS CONTROL	O	Bias oscillation control, H:ON
8	REC/PB	O	REC/PB selection
9	SPEED X1/X2	O	Tape speed selection
10	T2 AUTO SPACE	I	Auto space operation
11	T2 REC/PAUSE	I	REC/PAUSE operation
12	T2 FWD-PALY	I	FWD-PLAY operation
13	T2 REV-PALY	I	REV-PLAY operation
14	T2 FF	I	Fast forward operation
15	T2 REW	I	Rewind operation
16	X2 DUBBING	I	Dubbing operation
17	X1 DUBBING	I	Dubbing operation
18	T1 ROTATION-SENSOR	I	Reel rotation sensor
19	T2 ROTATION-SENSOR	I	Reel rotation sensor
20	METAL SW.	I	Record equalizer selection (METAL)
21	T2 SIDE-A REC. INH.	I	Recording prevention
22	T2 CASSETTE IN	I	Cassette loading detection (SIDE-A)
23	CrO ₂ SW.	I	Record equalizer selection (HIGH)
24	T2 SIDE-B REC. INH.	I	Recording prevention (SIDE-B)
25	T1 CASSETTE IN	I	Cassette loading detection
26	MODE 	I	Reverse mode selection
27	P-OFF	I	Power OFF detection
28	T1 CAPSTAN ON/OFF	O	Capstan motor control
29	T2 CAPSTAN ON/OFF	O	Capstan motor control
30	T1 SPEED X2/X1	O	Tape speed control
31	T2 SPEED X2/X1	O	Tape speed control
32	V _{CC}		V _{CC} +5V
33	NRSC IN	I	Remote control signal
34	NRSC OUT	O	Remote control signal
35	LINE MUTE	O	Line muting
36	NOT USED		
37	T2 REEL-FF	O	Reel motor rotation fast forward
38	T2 REEL-REW	O	Reel motor rotation in rewind
39	T2 O-PLAY	O	Reel motor rotation PLAY with "H"
40	T2 SOLENOID	O	Solenoid drive
41	T1 REEL-FF	O	Reel motor rotation fast forward
42	T1 REEL-REW	O	Reel motor rotation in rewind
43	T1 O-PLAY	O	Reel motor rotation PLAY with "H"
44	T1 SOLENOID	O	Solenoid drive
45	T1 REW	I	Key input to cause rewind
46	T1 FF	I	Key input to cause fast forward
47	T1 REV-PALY	I	Key input to casue REV-PLAY
48	T1 FWD-PALY	I	Key input to cause FWD-PLAY
49	SYSTEM RESET		System reset for microcomputer
50	TEST		
51, 52	OSC1, OSC2		System clock OSC
53	GND		GND
54	NOT USED		
55	NOT USED		
56	FT		
57	DOLBY ENC/DEC	O	Dolby ENC/DEC selector
58	TAPE SEL. METAL	O	Tape selector
59	TAPE SEL. HIGH	O	Tape selector
60	TAPE SEL. NORMAL	O	Tape selector
62	T2 FWD. LED	O	FWD indication, H:ON
61	T2 REV. LED	O	REV indication, H:ON
59	T2 REC. LED	O	REC indication, H:ON
60	T2 PAUSE LED	O	PAUSE indication

MICRO COMPUTER (HD614049SA83)

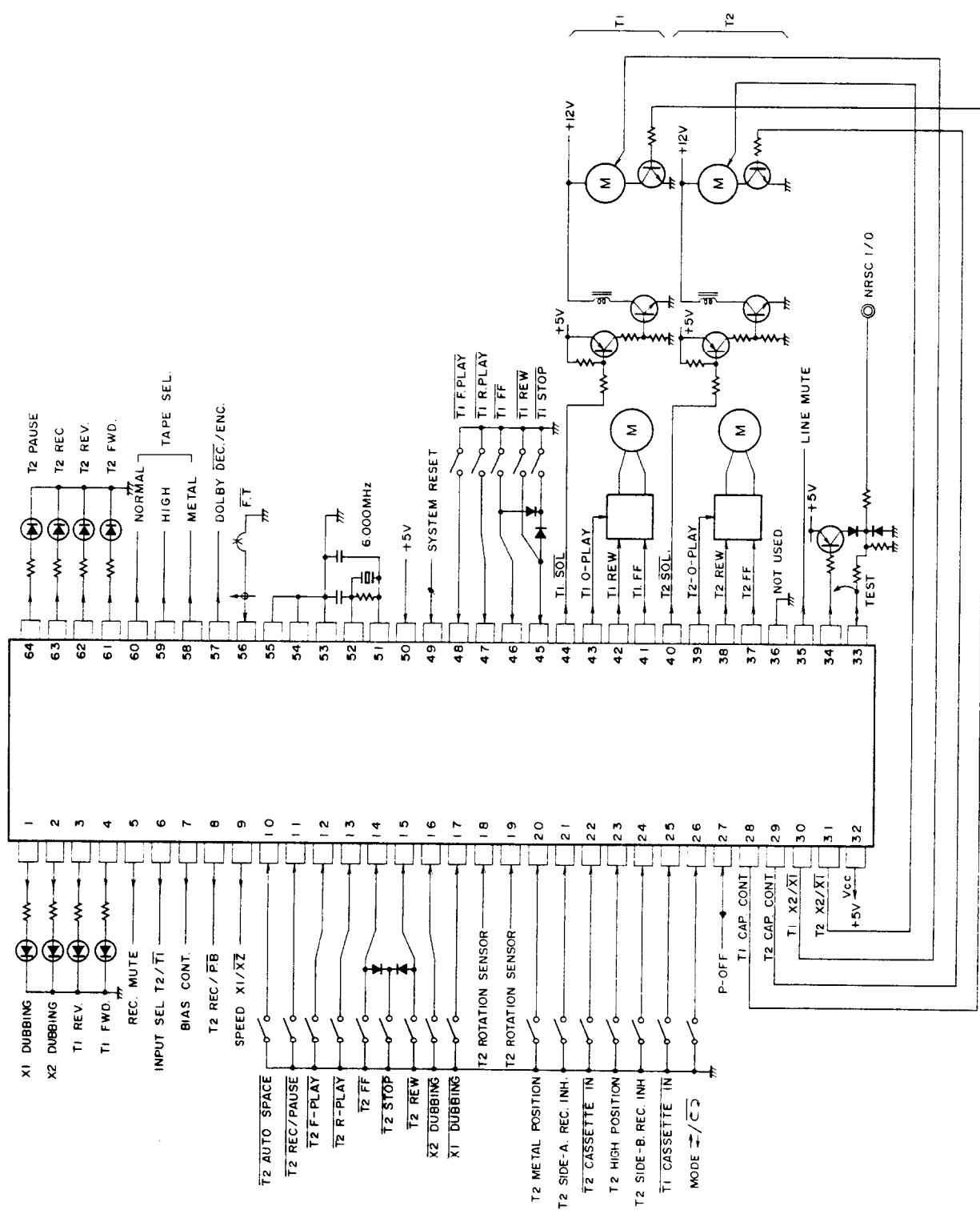

ADJUSTMENT PROCEDURES

PRECAUTIONS

- Before adjustment, clean the following parts with an alcohol moistend swab.
 - * record/playback head
 - * pinch roller
 - * erase head
 - * capstan
- Do not use magnetized screwdriver for adjustments.
- Demagnetize record/playback head with a head demagnetizer.

TEST EQUIPMENT/TOOLS REQUIRED:

- Audio oscillator
- Digital frequency counter
- Oscilloscope
- Attenuator
- AC voltmeter
- Non-magnetic screw driver
- Test tapes
 - TCC-153 : 10 KHz, - 5dB
 - MTT-111 : 3 kHz, - 0dB
 - MTT-150 : Dolby level calibration
400Hz, tone 200nWb/m

Item	Connection of instrument	Line input	Test tape	Mode	Output indicator	Adjustment point	Adjust	Remarks
1	Tape speed Frequency counter to LINE output terminal		MTT-111	PB	Frequency counter	T1 Normal R728 T1 High R731 T2 Normal R747 T2 High R750	3005±5Hz 6010±10Hz 3005±5Hz 6010±10Hz	High speed connect the TP5 (T1) to GND TP-6 (T2) to GND High speed first
2	Head azimuth AC voltmeter and oscilloscope to LINE output terminal		TCC-153	PB	AC voltmeter	Haed azimuth screw	Maximum and same phase at channels L and R	fig-1
3	Play-back level AC voltmeter to terminals TP-3 and TP-4		MTT-150	PB	AC voltmeter	T1 R113 (Ch.L) T1 R114 (Ch.R) T2 R131 (Ch.L) T2 R132 (Ch.R)	300mV	
4	OSC Block Frequency counter to P401 read loose coupling		T2 METAL TAPE MX-C90	T2 REC	Frequency counter	L403	85kHz±2kHz	
5	HX-PRO AC voltmeter to terminals TP-1 and TP-2		METAL TAPE	REC	AC voltmeter	L-405 (Ch.L) L-406 (Ch.R)	Maximum	R-473 R-474 clock wise (max)
6	Bias current fig-2	1kHz, -20dB and 12kHz, -20dB	XL-II C-90	REC/PB	AC voltmeter	R473 (Ch.L) R474 (Ch.R)	Same level at REC/PB	Input VR maximum.
7	Record level fig-2	1kHz	XL-II C-90	REC	AC voltmeter	Attenuator or AF OSC output	350mV	
				REC/PB	AC voltmeter	R405 (Ch.L) R406 (Ch.R)	Same level at REC/PB	

Blank tape

NORMAL UD-1 C-90

HIGH XL-II C-90

METAL MX C-90

PLAY torque 30~70g/cm

FF. REW torque 80~180g/cm

Back tention 2~7g/cm

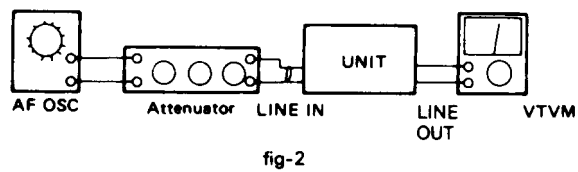
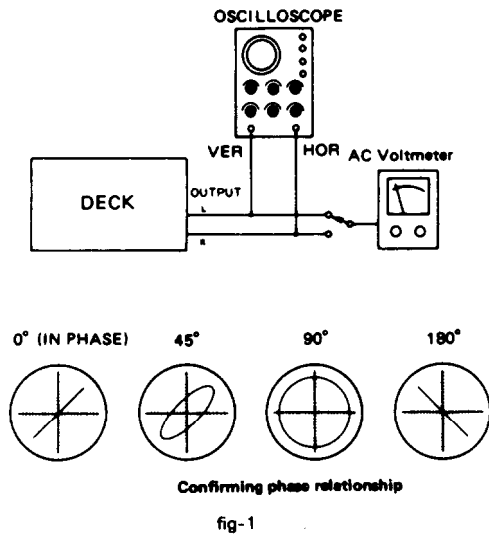
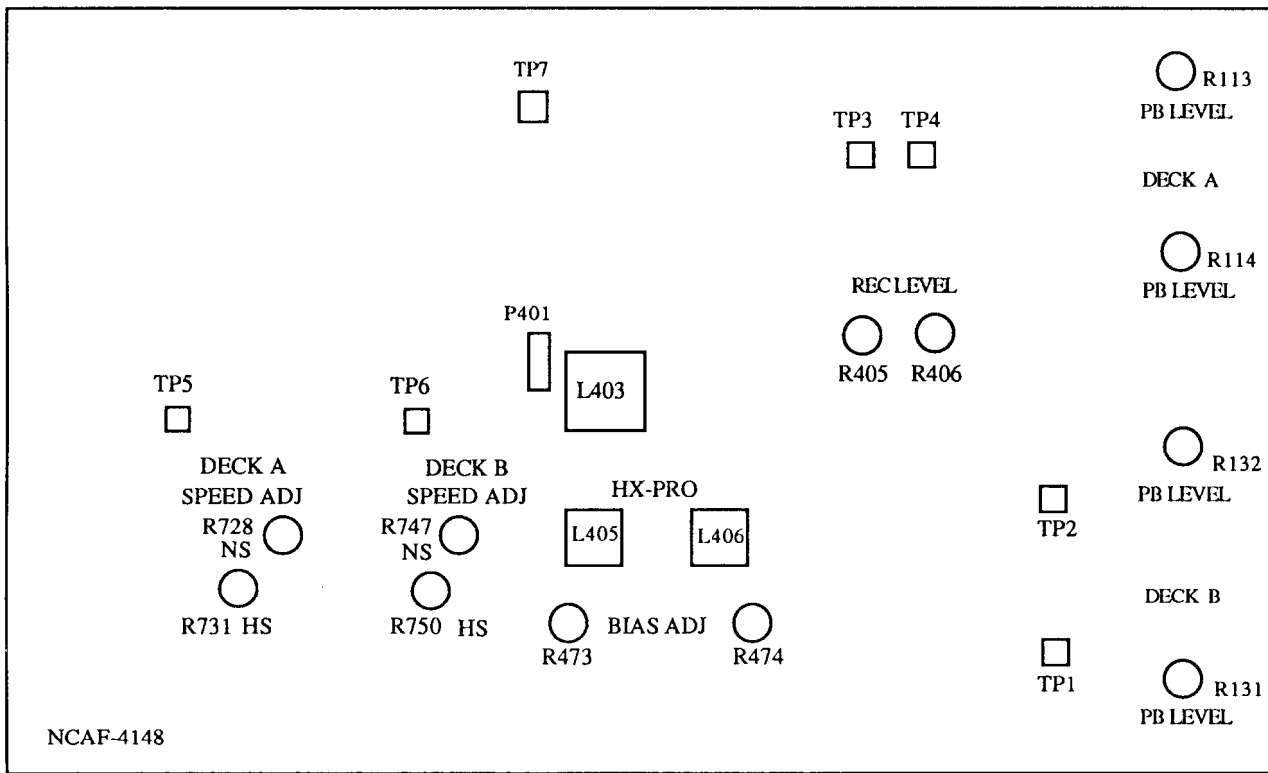

CHASSIS-EXPLODED VIEW PARTS LIST

REF. NO.	PARTS NO.	DESCRIPTION	REF. NO.	PART NO.	DESCRIPTION
A1	27110617A	FRONT BRACKET AS	U1	1N09548-2	NAAF-4148-2
A3	27273135A	JOINT (POW)	U2	1N09549-2	NADIS-4149-2
A5	24601220	TAPE COUNTER	U3	1N09550-2	NASW-4150-2
A6	28400282	DAMPER	U4	1N09551-2	NAETC-4151-2
A7	27180476	SPRING (A)	Z1	<u>244148</u>	CASSETTE DECK-A MECHANISM
A8	27180477	SPRING (B)	Z2	<u>244149</u>	CASSETTE DECK-B MECHANISM
A9	27130646B	BRACKET (F)			
A11	28400473-1A	FRAME AS (CASSETTE)			
-a	28400463B	FRAME (CASSETTE)			
-b	27180435	SPRING			
-c	28141109	CUSHION			
A12	27100233	CHASSIS			
A13	27190480	HOLDER			
A15	27121413	BACK PANEL (D)			
	27121413-1	BACK PANEL (G)			
	27121413-3	BACK PANEL (W)			
A16	27300750	BUSHING (CORD)			
A18	834430088	TAP-TIGHT SCREW 3TTS+8B (BC)			
A19	833430080	TAP-TIGHT SCREW 3TTP+8P (BC)			
A20	831130088	TAP-TIGHT SCREW 3TTW+8B			
A21	830440069	TAP-TIGHT SCREW 4x6			
A25	27130608D	BRACKET (PT)			
A30L	<u>28184478</u>	TOP COVER - <u>C6012</u>			
A302	28140837	CUSHION 250x10x9t			
A303	<u>1N099121</u>	<u>FRONT PANEL</u>			
A304	28133258	BACK PLATE			
A305	28191586	CLEAR PLATE			
A307	<u>28400623</u>	CASSETTE LID AS (A) <u>C6046</u>			
-a	28400624	CASSETTE LID (A)			
-b	28400625	WINDOW			
A310	<u>28400623-1</u>	CASSETTE LID AS (B)			
-a	28400624-1	CASSETTE LID (B)			
-b	28400625	WINDOW			
A509	<u>27215207</u>	COSMETIC FRAME (D) <u>C5026</u>			
A631	27175254	LEG AS			
A801	28324232	KNOB (EJ)			
A802	<u>28324233</u>	<u>KNOB (DOL)</u>			
A803	28324338	KNOB (VOL)			
A804	28324234	KNOB (POW)			
W1	<u>253112A</u>	AC CORD AS-UC-4 #18 (D)			
	253149	AC CORD AS-CEE (G/W)			
T901	2300632	NPT-1100D (D)			
	2300633	NPT-1100P (G)			
	2300634	NPT-1100DG (W)			

NOTE (D): Only 120V model
 (G): Only 230V model
 (W): Only worldwide model

NOTE: THE COMPONENTS IDENTIFIED BY MARK  ARE CRITICAL FOR RISK OF FIRE AND ELECTRIC SHOCK. REPLACE ONLY WITH PART NUMBER SPECIFIED.

PRINTED CIRCUIT BOARD PARTS LIST

NAAF-4148-2

CIRCUIT NO.	PART NO.	DESCRIPTION	CIRCUIT NO.	PART NO.	DESCRIPTION
				2213284	2SC1740S-R
			Q905, Q906	2202115 or 2202116	2SD2061-E or 2SD2061-F
					Diodes
Q101, Q107	222956	NJM-2068D-D	D601-D603	223163	1SS133
Q111	222933 or 222840661	BU-4066B or 4066B	D701, D704	224450752	MTZ7.5B
Q201	22240388	HA12142NT	D702, D705	224450433	MTZ4.3C
Q301	22240368 or 222652	M5218AL or M5218L	D703	223163	1SS133
Q401	22240267	CXA1198AP	D706, D707	223163	1SS133
Q405	222840511	4051B	D708	224150562	05AZ5.6Y
Q413	222959	μPC1297CA	D709	223163	1SS133
Q605	22240147	μPC1330HA	D901-D906	22380046	AM01Z
Q701	22240454	HD614049SA83	D907, D908	223163	1SS133
Q702	22240239	HA-7291S	D909	224150623	05AZ6.2Z
Q710	22240239	TA-7291S	D910	224151303	05AZ13Z
Q901	222780075MIT	78M07L	D911, D912	223163	1SS133
Q902	222790075MIT	79M07L			Coils
Q903	222780055MIT	78M05	L201, L202	233407	NMC-6079
			L401, L402	231165	NTR-6506
			L403	231063	NLO-2037
			L405	231127	NCH-4183
					Crystal
Q103-Q106	2213285 or 2213284	2SC1740S-S or 2SC1740S-R	X701	3010149	CST6.00MGW
Q109, Q110	2213285 or 2213284	2SC1740S-S or 2SC1740S-R			Capacitors
Q113	221281 or 2213570	DTC114YS or RN1207	C111, C112	393142217	220 μF16V, ELECT.
Q203	221281 or 2213570	DTC114YS or RN1207	C123, C124	393142217	220 μF16V, ELECT.
Q205	2212600 or 2213580	DTA124ES or RN2203	C203-C206	393184797	0.47 μF50V, ELECT.
Q403, Q404	2213285 or 2213284	2SC1740S-S or 2SC1740S-R	C207	393142207	22 μF16V, ELECT.
Q407	221281 or 2213570	DTC114YS or RN1207	C213, C214	393180227	2.2 μF50V, ELECT.
Q408	2212855 or 2212853	2SB1068-U or 2SB1068-K	C217-C220	393181097	0.1 μF50V, ELECT.
Q409	2211706	2SD655-F	C221, C222	393180227	2.2 μF50V, ELECT.
Q411, Q412	2211544	2SC1959-Y	C401, C402	393180107	1 μF50V, ELECT.
Q415, Q416	221281 or 2213570	DTC114YS or RN1207	C404-C406	393180227	2.2 μF50V, ELECT.
Q601	221281 or 2213570	DTC114YS or RN1207	C407	393122217	220 μF6.3V, ELECT.
Q602	2213355 or 2213354	2SA933S-S or 2SA933S-R	C408	393144707	47 μF16V, ELECT.
Q603, Q604	2211706	2SD655-F	C411	370131234	0.012 μF100V, APS
Q703, Q704	221281 or 2213570	DTC114YS or RN1207	C421	370131014	100PF100V, APS
Q705	2211945 or 2212304	2SK246-GR or 2SK381-D	C427	393144707	47 μF16V, ELECT.
Q706	2212600 or 2213580	DTA124ES or RN2203	C601	393180477	4.7 μF50V, ELECT.
Q707, Q708	2211706	2SD655-F	C604	393184797	0.47 μF50V, ELECT.
Q709	2211255	2SC1815-GR	C701	393142207	22 μF16V, ELECT.
Q711, Q712	221281 or 2213570	DTC114YS or RN1207	C703	393141017	100 μF16V, ELECT.
Q713	2211945 or 2212304	2SK246-GR or 2SK381-D	C704	393184797	0.47 μF50V, ELECT.
Q714	2212600 or 2213580	DTA124ES or RN2203	C707	393141017	100 μF16V, ELECT.
Q715, Q716	2211706	2SD655-F	C708	393184797	0.47 μF50V, ELECT.
Q717	2211255	2SC1815-GR	C711	393180107	1 μF50V, ELECT.
Q718, Q719	2212600 or 2213580	DTA124ES or RN2203	C714, C715	393184797	0.47 μF50V, ELECT.
Q720	2212600 or 2213580	DTA124ES or RN2203	C901	3500065A	0.01 μF AC400V, IS.
Q904	2213285 or	2SC1740S-S or	C903	393152227S	2200 μF25V, ELECT.
			C904	393142217	220 μF16V, ELECT.
			C906	393152227S	2200 μF25V, ELECT.
			C907	393142217	220 μF16V, ELECT.
			C909	393156827S	6800 μF25V, ELECT.
			C910	393180107	1 μF50V, ELECT.
			C911	393142217	220 μF16V, ELECT.
			C913-C915	393141017	100 μF16V, ELECT.
			C916	393180477	4.7 μF50V, ELECT.
			C917	393144717	470 μF16V, ELECT.
			C919	393144717	470 μF16V, ELECT.
			C921	393142217	220 μF16V, ELECT.
			C923	393142217	220 μF16V, ELECT.
			C925, C926	393141017	100 μF16V, ELECT.
			C927	393141017	100 μF16V, ELECT.
			C929, C933	393141017	100 μF16V, ELECT.
			C931, C932	393141007	10 μF16V, ELECT.

PRINTED CIRCUIT BOARD PARTS LIST

CIRCUIT NO.	PART NO.	DESCRIPTION	CIRCUIT NO.	PART NO.	DESCRIPTION
Resistors			Switches		
R113, R114	5210220	N06HR50KBD	S201	25065297	NSS-23119, DOLBY
R131, R132	5210220	N06HR50KBD	S701-S705	25035548	NPS-111-S510
R405, R406	5210064	N06HR10KBD	S706	25065364	NSS-12138, MODE
R458	442520104F	RS1/2WBJ 1Ω	S707-S715	25035548	NPS-111-S510
R459	442524704F	RS1/2WBJ 47Ω	NAETC-4151-2		
R461	442522214F	RS1/2WBJ 220Ω	CIRCUIT NO. PART NO. DESCRIPTION		
R472	442523304F	RS1/2WBJ 33Ω	Variable resistor		
R473, R474	5210064	N06HR10KBD	R203, R204	5104214	N09R2L50kA15F
R724	442524704F	RS1/2WBJ 47Ω	Plug		
R728	5210218	N06HR20KBD	P301	25045255	YKBZ1-5009
R731	5210217	N06HR10KBD			
R743	442524704F	RS1/2WBJ 47Ω			
R747	5210218	N06HR20KBD			
R750	5210217	N06HR10KBD			
R903	441622704F	RS1/2WBJ 27Ω			
R905, R906	442520224F	RS1/2WBJ 2.2Ω			
R911, R912	442522704F	RS1/2WBJ 27Ω			
Switch					
S901	25035558	NPS-111-L520P			
Plug					
P101	25055133	NPLG-3P117			
P102	25055136	NPLG-6P120			
P201	25045329 or 25045338	NPJ-4PDBL183 or NPJ-4PDBL189			
P401	25055132	NPLG-2P116			
P701	25045330	NPJ-2PDBL184			
Socket					
P702A	2000991	NSAS-14P943			
P703A	2000992	NSAS-6P944			
P704A	2000990	NSAS-6P942			
P705A	2000991	NSAS-14P943			
P706A	2000992	NSAS-6P944			
P707A	2002391210	NSAS-12P0235			
Miscellaneous					
	27160211-1	RAD-68B, RADIATOR			
	27160211	RAD-68, RADIATOR			
	27141059	BRACKET			
	25060092	NTM-1S33			
	82143006	3P+6FN(BC), SCREW			

NADIS-4149-2

CIRCUIT NO.	PART NO.	DESCRIPTION
IC		
Q303, Q304	222623	IR2E02
LED		
D604	225253A	LS-0241
Capacitors		
C301, C302	353750479S	4.7 μF25V, ELECT.
C303, C304	353780109S	1 μF50V, ELECT.
C305	353750479S	4.7 μF25V, ELECT.
Socket		
P708A	2000985A	NSAS-18P937

NASW-4150-2

CIRCUIT NO.	PART NO.	DESCRIPTION
Diode		
D710-D713	223163	1SS133

IC BLOCK DIAGRAM

IR-2E02 (LEVEL METER DRIVE)

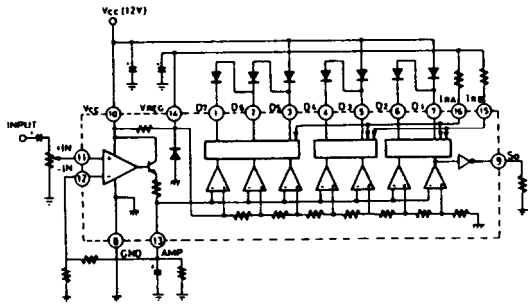

TA-7291S (MOTOR DRIVE)

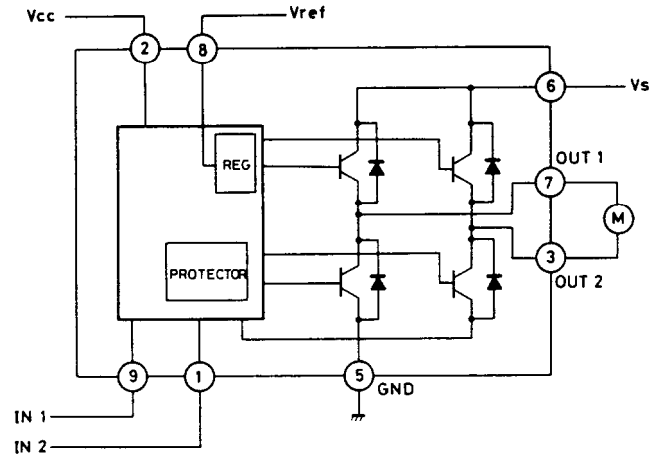

4066B (ANALOG SW)

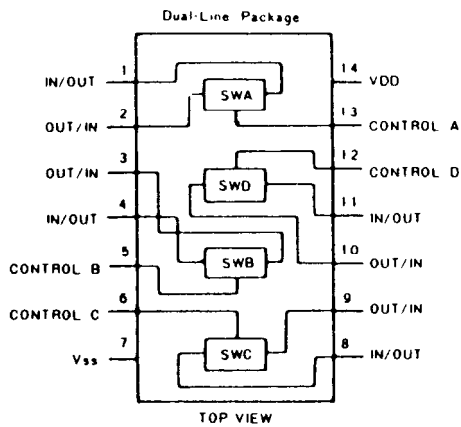

INPUT		OUTPUT		MODE
IN 1	IN 2	OUT 1	OUT 2	
0	0	∞	∞	STOP
1	0	H	L	CW/CCW
0	1	L	H	CCW/CW
1	1	L	L	BRAKE

LS. 0241 (DISPLAY TUBE)

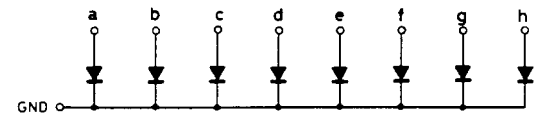
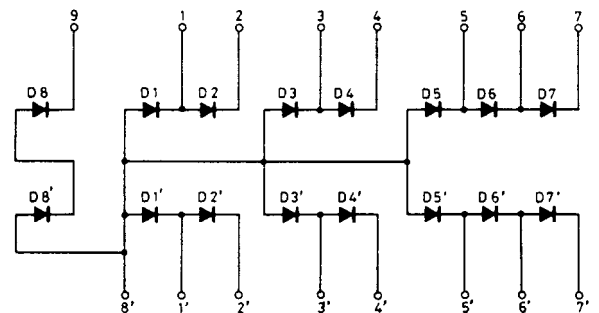
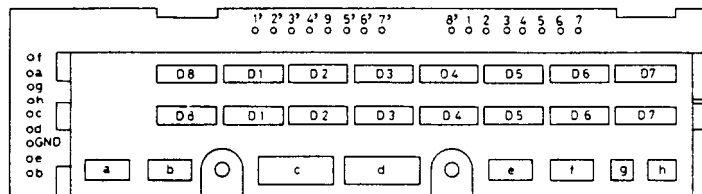

D1 ~ D4, D8, D1' ~ D4' D8; a, b, e, f, ----GRN
D5 ~ D7, D5' ~ D7'; c, d, g, h ----- RED

TAPE MECHNISM PARTS LIST (DECK-B)

REF.NO.	PARTS NO.	DISCRIPTION
2-1	24602482	IDLER AS
2-2	24601245	REEL MOTOR
2-3	24611382A	BASE AS (CHASSIS)
2-4	24602483	BASE AS (REEL)
2-5	24602484	BASE AS (REEL)
2-7	24609032	PAN HEAD SCREW 2.6×6.4ZN
2-8	24611177	PLASTIC WASHER 1.7×3.2×.25
2-11	24611175	PLASTIC WASHER 2.1×7×.25
3	24611428	R/ P HEAD AS
3-5	24611383B	BASE (HEAD)
3-9	24605711	SPRING
3-11	833120059	TAPPING SCREW 2×5ZN
4	24601252	MAIN MOTOR AS
5	24606334	P.C.B. AS (CONTROL)
5-13	24606319	GP2S04B
5-17	24606271	PUSH SWITCH
7	24607041B	ARM (PROTECT) R
8	24605739	SPRING
9	24611384A	SLIDE PLATE
10	24611385	LEAD HOLDER
12	24607101	ARM (PLAY)
14	24602485A	CAM GEAR (3R)
15	24603365A	LEVER (REC)
16	24603369	LEVER (PACK)
17	24603367	LEVER (METAL)
18	24602486	MAIN BELT
20	24611041	PLASTIC WASHER 2.6×0.25
23	24610841	PLASTIC WASHER 2.6×4.7×.5
25	24605714	SPRING (R)
26	24605716	SPRING
29	24602487	FLYWHEEL AS
30	24602528	FLYWHEEL AS
31	24602414C	PINCH ROLLER AS (R)
32	24602421C	PINCH ROLLER AS
36	24609001	PAN HEAD SCREW SW2.6×5ZN
37	24609006A	SCREW
39	8930151	E WASHER 1.5S
40	838130080	WAVE SCREW 3×8
43	24611488	CUSHION (HOLDER)
51	24606333	SOLENOID COIL AS
52	24606332A	CORE
53	24606331	PLANGER
61	24611429	PLATE HOLDER AS
62	833126049	TAP-TIGHT SCREW 2.6TTP+4C
63	24611188A	WASHER (OIL SEAL)
64	24610844	WASHER 1.9×5×0.25
65	24611389	PLATE HOLDER AS
66	24607099	EJECT ARM (A)
67	24609002	SCREW 2.0×4ZN
69	838126080	SCREW 2.6×8
70	24611323	LUG
84	24606459	WIRE CONNECTOR (R/P)

TAPE MECHNISM PARTS LIST (DECK-A)

REF.NO.	PARTS NO.	DISCRIPTION
2-1	24602482	IDLER AS
2-2	24601245	REEL MOTOR
2-3	24611382A	BASE AS (CHASSIS)
2-4	24602483	BASE AS (REEL)
2-5	24602484	BASE AS (REEL)
2-7	24609032	PAN HEAD SCREW 2.6×6.4ZN
2-8	24611177	PLASTIC WASHER 1.7×3.2×.25
2-11	24611175	PLASTIC WASHER 2.1×7×.25
3	24600087	P HEAD AS
3-5	24611383B	BASE (HEAD)
3-9	24605711	SPRING
3-11	833120059	TAPPING SCREW 2×5ZN
4	24601252	MAIN MOTOR AS
5	24606334	P.C.B. AS (CONTROL)
5-13	24606319	GP2S04B
5-17	24606271	PUSH SWITCH
7	24607065B	ARM (PROTECT) R
8	24605739	SPRING
9	24611384A	SLIDE PLATE
10	24611385	LEAD HOLDER
12	24607101	ARM (PLAY)
14	24602485A	CAM GEAR (3R)
15	24603365A	LEVER (REC)
16	24603369	LEVER (PACK)
18	24602486	MAIN BELT
20	24611041	PLASTIC WASHER 2.6×0.25
23	24610841	PLASTIC WASHER 2.6×4.7×.5
25	24605762	SPRING (R)
26	24605716	SPRING
29	24602487	FLYWHEEL AS
30	24602528	FLYWHEEL AS
31	24602414C	PINCH ROLLER AS (R)
32	24602421C	PINCH ROLLER AS
36	24609001	PAN HEAD SCREW SW2.6×5ZN
37	24609006A	SCREW
39	8930151	E WASHER 1.5S
40	838130080	WAVE SCREW 3×8
43	24611488	CUSHION (HOLDER)
51	24606333	SOLENOID COIL AS
52	24606332A	CORE
53	24606331	PLANGER
61	24611426	PLATE HOLDER AS
62	833126049	TAP-TIGHT SCREW 2.6TTP+4C
63	24611188A	WASHER (OIL SEAL)
64	24610844	WASHER 1.9×5×0.25
69	838126080	SCREW 2.6×8
70	24611323	LUG
84	24606460	WIRE CONNECTOR (P/B)

A B C D E F G

TAPE MECHANISM-EXPLODED VIEW (DECK-A)

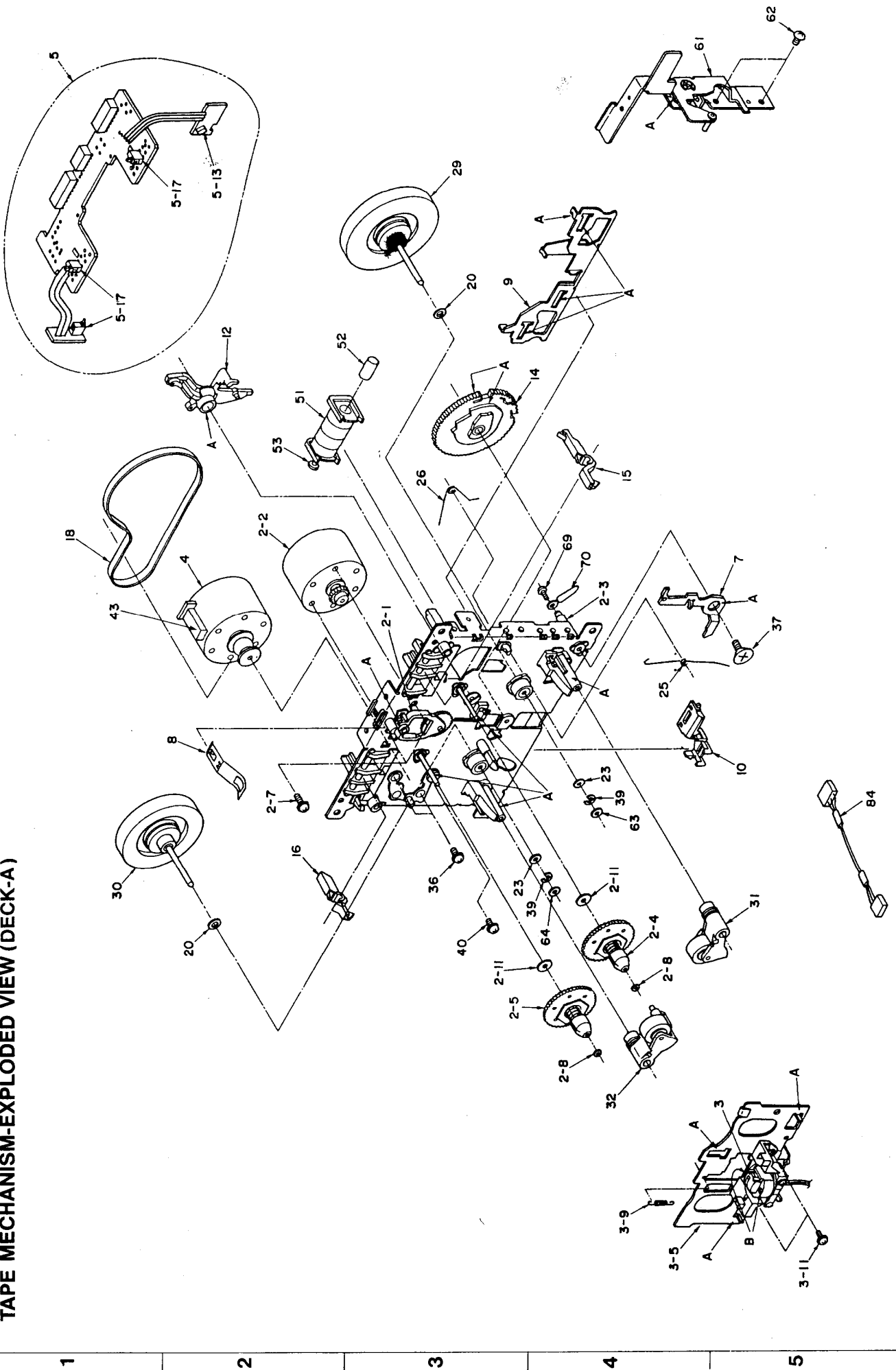

1 2 3 4 5

TAPE MECHANISM-EXPLODED VIEW (DECK-B)

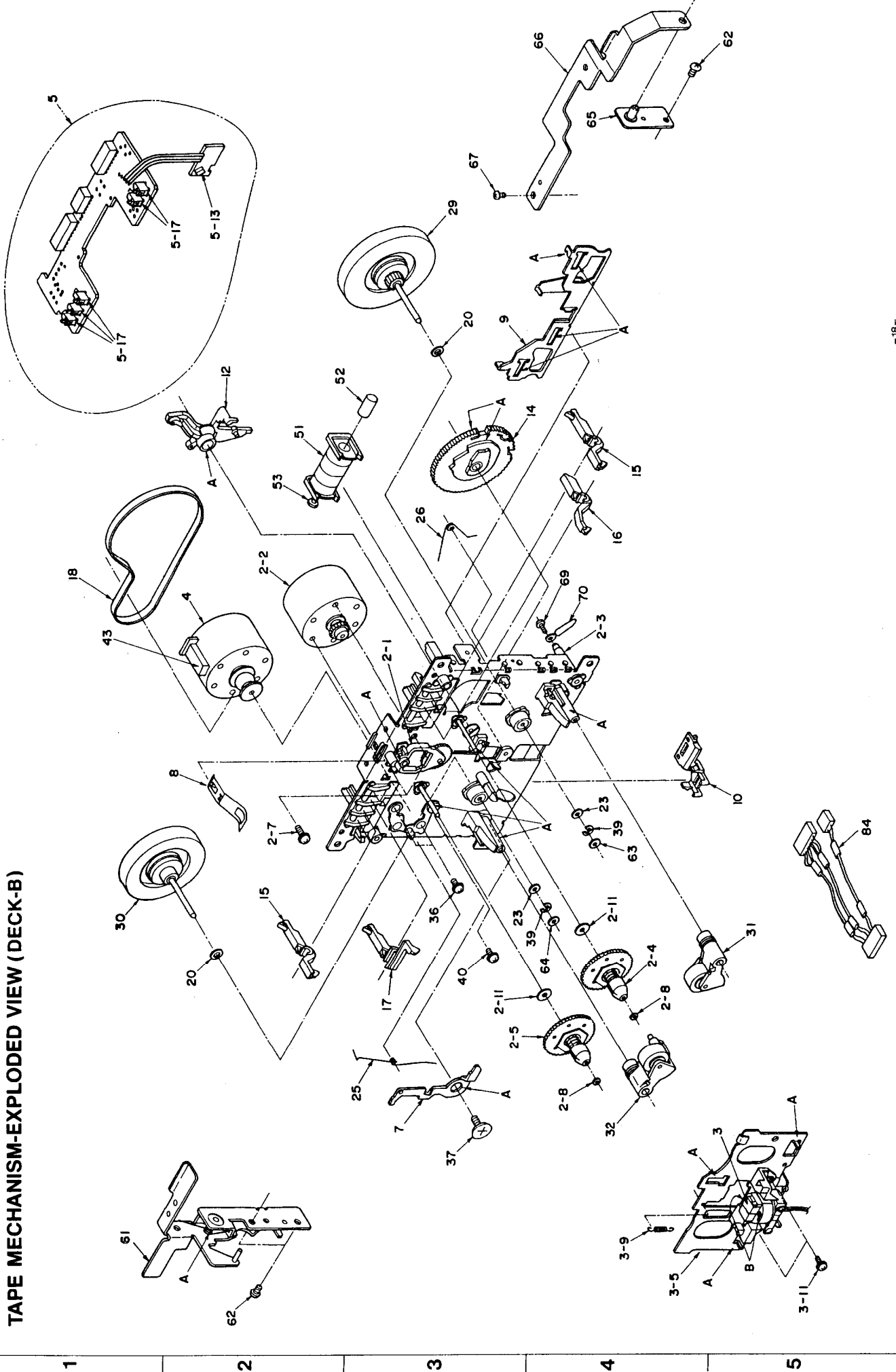
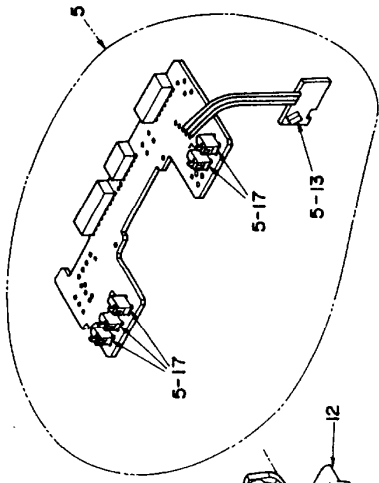

SCHEMATIC DIAGRAM (AUDIO SECTION) 1/2

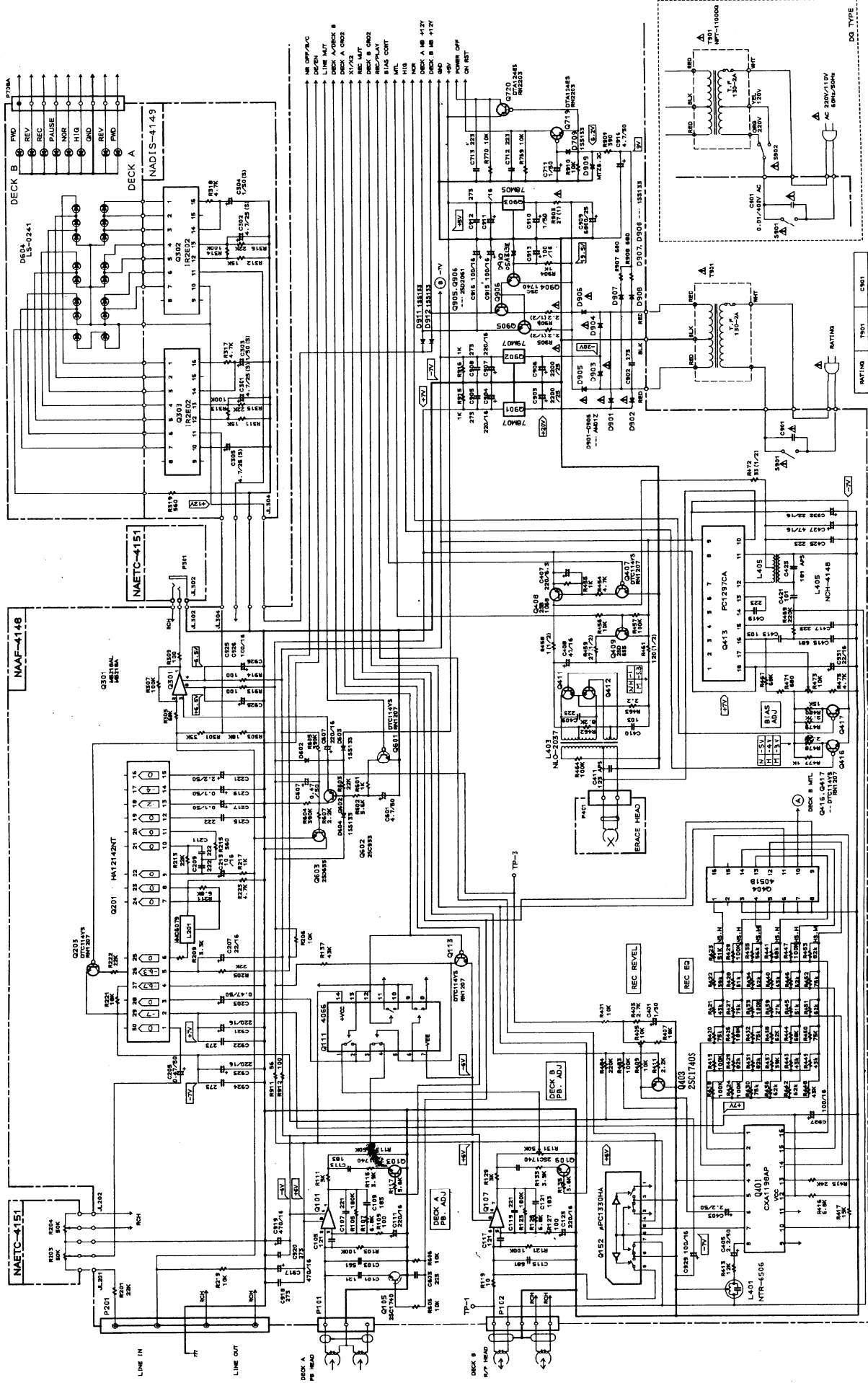

SCHEMATIC DIAGRAM (CONTROL SECTION) 2/2

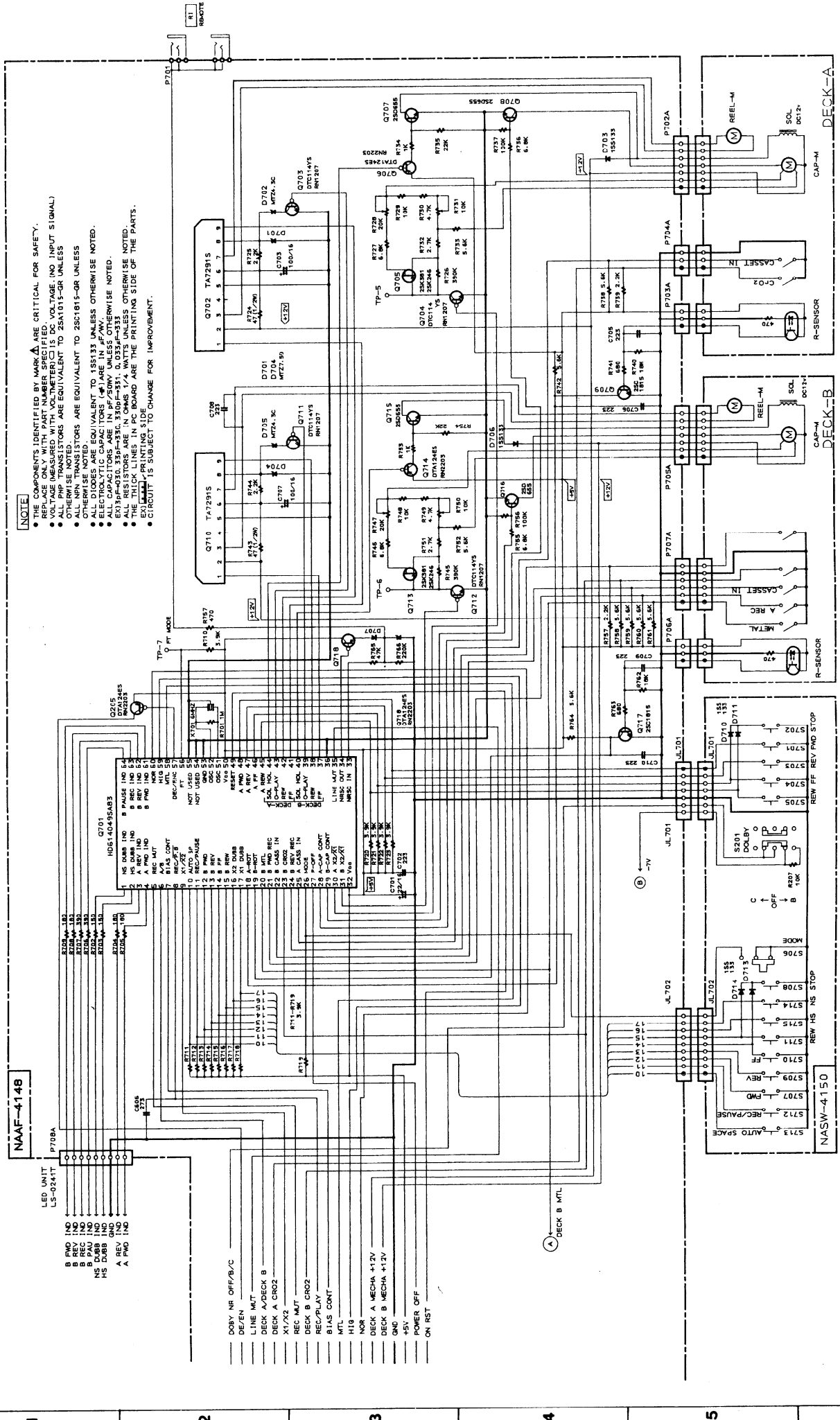

NOTE

- THE COMPONENTS IDENTIFIED BY MARK Δ ARE CRITICAL FOR SAFETY.
- REPLACE ONLY WITH PART NUMBER SPECIFIED.
- VOLTAGE MEASURED WITH VOLTMETER \square IS DC VOLTAGE, (NO INPUT SIGNAL).
- RESISTOR VALUES ARE EQUIVALENT TO 250V015-GR UNLESS OTHERWISE NOTED.
- ALL PNP TRANSISTORS ARE EQUIVALENT TO 2SC1815-GR UNLESS OTHERWISE NOTED.
- ELECTROLYTIC CAPACITORS \square ARE IN μ F/VV.
- OTHERWISE NOTED EQUIVALENT TO 1S513Z UNLESS OTHERWISE NOTED.
- ALL CAPACITORS ARE IN P/F/50V UNLESS OTHERWISE NOTED.
- EX3 RESISTORS PREC. 320P/0.5%, UNLESS OTHERWISE NOTED.
- THE THICK LINES IN PC BOARD ARE THE PRINTING SIDE OF THE PARTS.
- EX-PRINTING SIDE
- CIRCUIT IS SUBJECT TO CHANGE FOR IMPROVEMENT.

PACKING VIEW

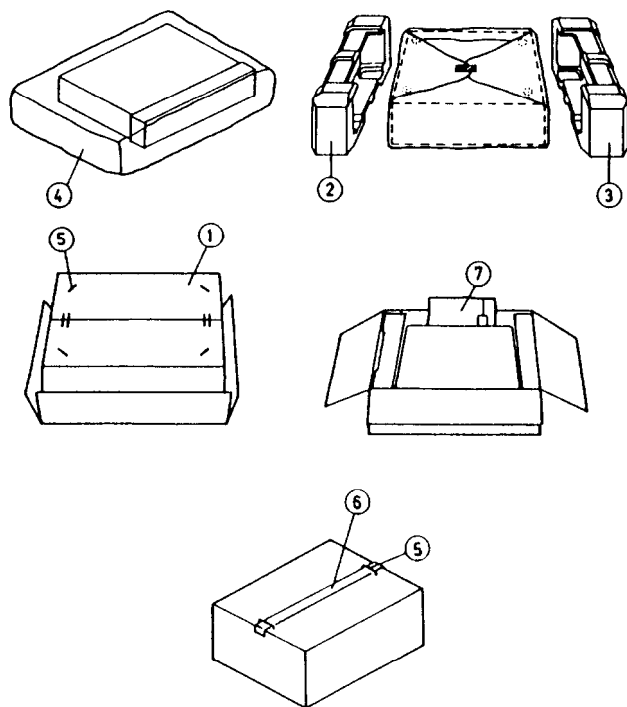

PART LIST

REF. NO.	PART NO.	DESCRIPTION
1	29052163	Master carton box
2	29091452A	Pad (L)
3	29091453A	Pad (R)
4	29100105	620×550 Poly bag
5	282301	Sealing hook
6	29110071	Damplon tape
7		Accessory bag ass'y
	29341602	Instruction manual (D)
	29341604	Instruction manual (G/W)
	2010098A	Connection cable
	29365024	Warranty card (F)
	29100107	Poly bag (F)
	29365019A	Warranty card (N)
	29358002J	Service station list (N)
	29100006A	350×250 Poly bag
	25055018	Conversion plug (CV-K-2) (W)

NOTE (D): Only 120V model
 (G): Only 230V model
 (W): Worldwide model
 (F): Only FRANCE model
 (N): Only U.S.A. model

ONKYO CORPORATION

International Division: Onarimon Yusen Bldg., 23-5, Nishi-Shimbashi 3-chome, Minato-ku,
 TOKYO 105, JAPAN Tel: 03-3432-6987 Fax: 03-3436-6979

ONKYO U.S.A. CORPORATION

200 Williams Drive, Ramsey, N.J. 07446, U.S.A. Tel: 201-825-7950 Fax: 201-825-8150

ONKYO Europe GmbH

Hellersbergstrasse 4, W-4040 Neuss, GERMANY
 Tel: 02101 12 00 75 Fax: 02101 10 33 06 TLX: 85 17 916 ONDU D

ONKYO FRANCE S.A.R.L.

Immeuble Le DIAMANT, Domaine Technologique De Saclay, 4 rue Rene Razel, 91892 SACLAY,
 FRANCE Tel: (1)69 41 35 10 FAX: (1)69 41 35 84